

# AL-SB Installation Instructions

Read all instructions before beginning installation process

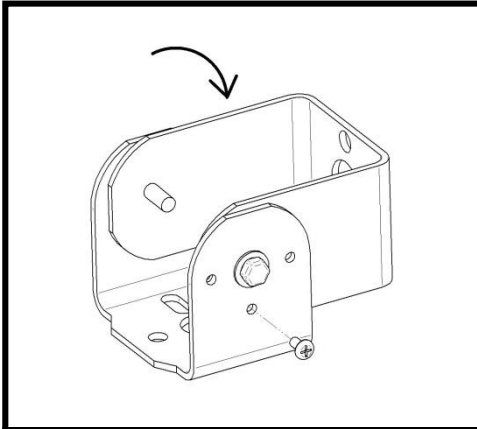

1. Remove #10 screw to unlock rotation of the Swivel Bracket. Adjust the bracket to a 90-degree angle.

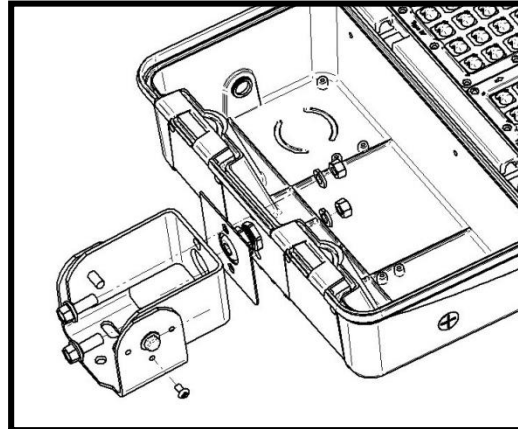

2. Install the Swivel Bracket oriented as shown using the provided hardware. Gasket must be placed between the Bracket and the casting to preserve IP rating. Tighten nuts to 12-15 ft-lbs.

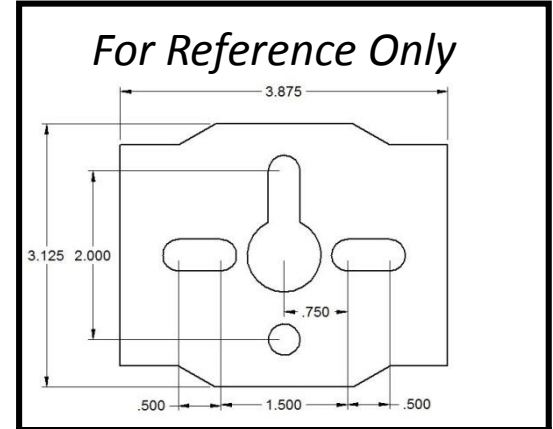

3. Reference the included drawing to mark hole locations on the intended mounting surface. Pre-drill holes as needed. AL-SB is intended to be mounted with 3/8" lag screws or concrete anchors (provided by others).

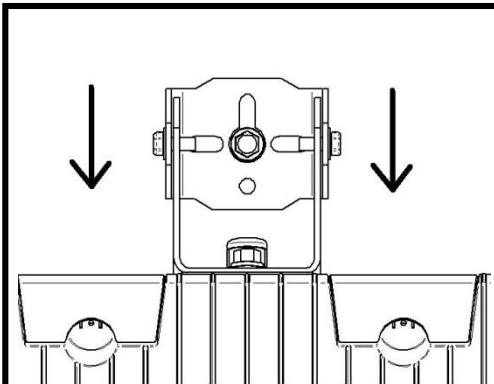

4. Screw in the top bolt/anchor until the head is about 1/4" from the mounting surface. Slide the large portion of the keyhole slot over the bolt and slide the fixture down until the bolt touches the top of the keyhole.

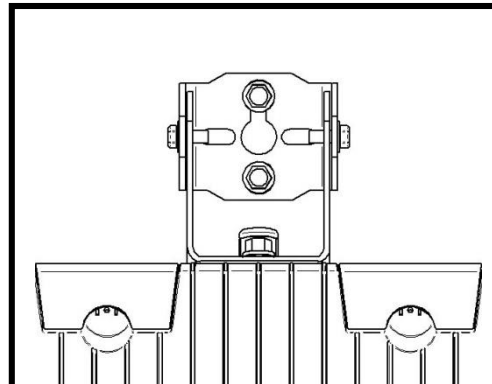

5. Install the remaining bolts/anchors, and tighten all to 18-20 ft-lbs. Complete all wiring and close and latch the driver compartment.

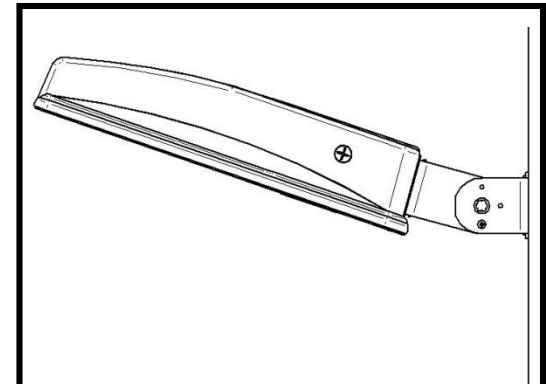

6. Adjust fixture to the desired angle and lock the bracket in place by reinstalling the #10 screw. Tighten the bolts on the sides of the bracket to 10 ft-lbs.

**FOR DIMENSION REFERENCE ONLY!  
DRAWING MAY NOT PRINT TO SCALE**

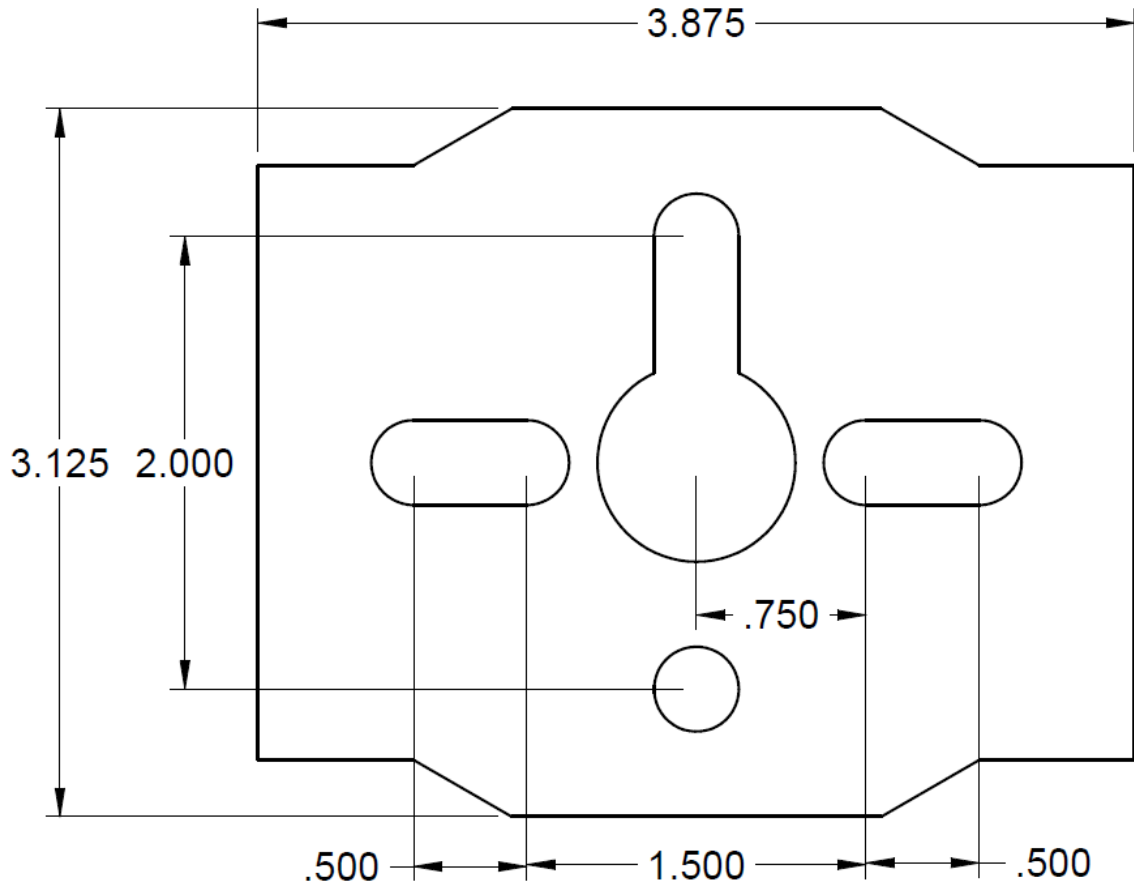

REVISION HISTORY			
REV	DESCRIPTION	DATE	APPROVED



Industrial Lighting Products  
339 Codriss Way Sanford, FL 32771

FILE TYPE	B	AL-SB MOUNTING TEMPLATE	REV	
MATERIAL	Steel			
SCALE	GAUGE			

UNLESS OTHERWISE SPECIFIED DIMENSIONS ARE IN INCHES ANGLES ±2.0° 2 PL ±0.020 3 PL ±0.005	DRAWN	J FIELD	DATE	12/23/18
	CHECKED			
	ENG APPR			
	MGR APPR			

GENERAL NOTES: