



Bolt-On-Board LED Retrofit Kit – Installation Instructions

For BOB-23WLED-2BD Models Only



WARNING – RISK OF FIRE OR ELECTRIC SHOCK. LUMINAIRE WIRING AND ELECTRICAL PARTS MAY BE DAMAGED WHEN DRILLING FOR INSTALLATION OF LED RETROFIT KIT. CHECK FOR ENCLOSED WIRING AND COMPONENTS

AVERTISSEMENT - RISQUE D'INCENDIE OU DE CHOC ÉLECTRIQUE. CÂBLAGE DU LUMINAIRE ET PIÈCES ÉLECTRIQUES PEUVENT ÊTRE ENDOMMAGÉS LORS DU PERÇAGE POUR L'INSTALLATION DU KIT DE CONVERSION À DEL. VÉRIFIER LE CÂBLAGE ET LES COMPOSANTS CLOS



WARNING – RISK OF FIRE OR ELECTRIC SHOCK. LED RETROFIT KIT INSTALLATION REQUIRES KNOWLEDGE OF LUMINAIRES ELECTRICAL SYSTEMS. IF NOT QUALIFIED, DO NOT ATTEMPT INSTALLATION. CONTACT A QUALIFIED ELECTRICIAN.

ATTENTION - RISQUE DE FEU OU DE CHOC ÉLECTRIQUE. L'INSTALLATION DU KIT DE RÉNOVATION LED NÉCESSITE DES CONNAISSANCES SUR LES SYSTÈMES ÉLECTRIQUES DES LUMINAIRES. SI VOUS N'ÊTES PAS QUALIFIÉS, N'ESSEYEZ PAS DE L'INSTALLER. CONTACTER UN ÉLECTRICIEN QUALIFIÉ.



WARNING – RISK OF FIRE OR ELECTRIC SHOCK. INSTALL THIS KIT ONLY IN LUMINAIRES THAT HAVE THE CONSTRUCTION FEATURES AND DIMENSIONS SHOWN IN THE PHOTOGRAPHS AND/OR DRAWINGS AND WHERE THE INPUT RATING OF THE RETROFIT KIT DOES NOT EXCEED THE INPUT RATING OF THE LUMINAIRE.

ATTENTION - RISQUE DE FEU OU DE CHOC ÉLECTRIQUE. INSTALLER CE KIT UNIQUEMENT DANS LES LUMINAIRES DONT LES CARACTÉRISTIQUES ET LES DIMENSIONS CORRESPONDENT À CELLES INDIQUÉES DANS LES PHOTOS ET SCHÉMAS



WARNING – TO PREVENT WIRING DAMAGE OR ABRASION, DO NOT EXPOSE WIRING TO EDGES OF SHEET METAL OR OTHER SHARP OBJECTS.

ATTENTION - AFIN D'ÉVITER TOUTE ABRASION OU DOMMAGE DU CÂBLAGE ÉLECTRIQUE, NE PAS L'EXPOSER AUX ARRÊTES DES FEUILLES MÉTALLIQUES OU TOUT AUTRE OBJET TRANCHANT



THE RETROFIT KIT IS ACCEPTED AS A COMPONENT OF A LUMINAIRE WHERE THE SUITABILITY OF THE COMBINATION SHALL BE DETERMINED BY CSA OR AUTHORITIES HAVING JURISDICTION



THIS RETROFIT KIT IS SUITABLE FOR NON-IC, ENCLOSED RECESSED LUMINAIRES IN DRY OR DAMP LOCATIONS ONLY



ONLY THOSE HOLES INDICATED IN THE PHOTOGRAPHS AND/OR DRAWINGS MAY BE ALTERED AS A RESULT OF KIT INSTALLATION. DO NOT LEAVE ANY OTHER OPEN HOLES IN AN ENCLOSURE OF WIRING OR ELECTRICAL COMPONENTS.

Parts included in this kit:

LED Board			x2
LED Driver			x1
#6 hex head self-drilling screw			x7
#8 hex head self-drilling driver screw			x2
Blue wire nut			x3
AC power quick-disconnect			x1
12 in. green ground wire			x1
Ground Marker Label			x1
Identification Label			x1
	7 inches	12 inches	20 inches
Plain white wire	x2	x2	x1
Striped white wire	x1	x1	x1
Black wire	x1	x1	

Tools required:



Wire cutter



Cordless Drill with ¼" Hex Socket

Installer Notes:

- 1) Do not touch LEDs at any point during installation, at risk of damaging them. Anti-static or ESD equipment can be used to reduce the risk of damage.
- 2) A set of labels with model, date of manufacture, and ground marker are included in packaging and must be adhered within the luminaire during installation. All of these labels must be applied in compliance with UL standards.
- 3) Examine all parts that are not intended to be replaced by the retrofit kit for damage and replace any damaged parts prior to installation of the retrofit kit.
- 4) Prior to installation, positioning of retrofit components should be considered with respect to wire lengths, ballast cover placement, and ensuring optimal light output. For fixtures with parabolic louvers, LED boards should be placed in the center of cells.
- 5) It is recommended that a single test unit is installed before full renovation to ensure fixture compatibility.

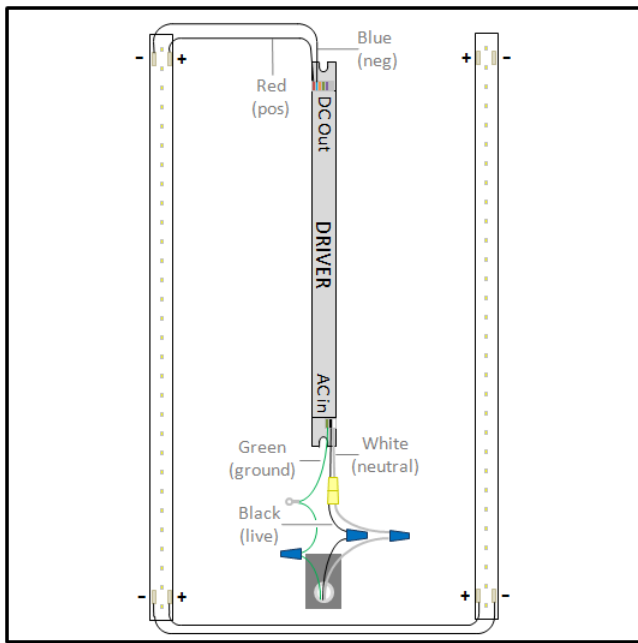

Diagram A: 2' x 2' Troffer Layout and Wiring:
Mount LED boards approximately 5"
from the fixture center.

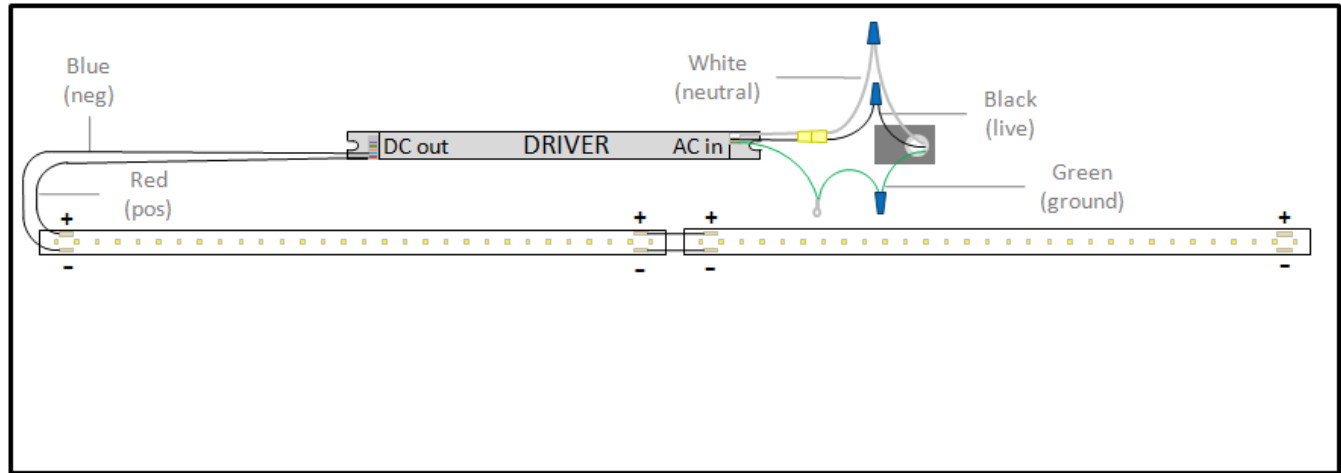
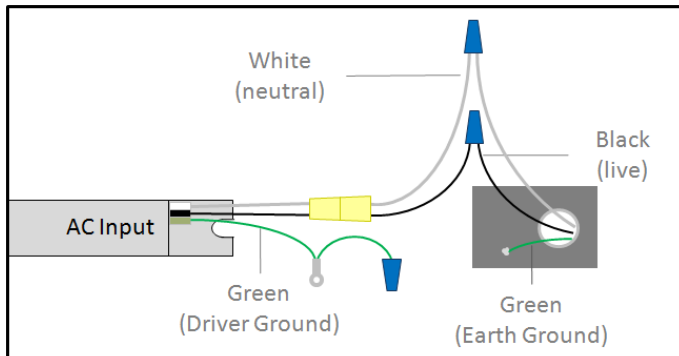

Diagram B: 1' x 4' Troffer Layout and Wiring:
Mount LED boards along the fixture center. In some fixtures it may be
necessary to mount the LED boards onto the fluorescent ballast cover.

Grounding Scenario 1:
If incoming Ground is
attached to fixture
housing, use a wire nut
to cap the loose end of
the provided ground
wire.



Grounding Scenario 2:
If incoming Ground is
not attached to fixture
housing, use a wire nut
to attach incoming
ground with the loose
end of the provided
ground wire.

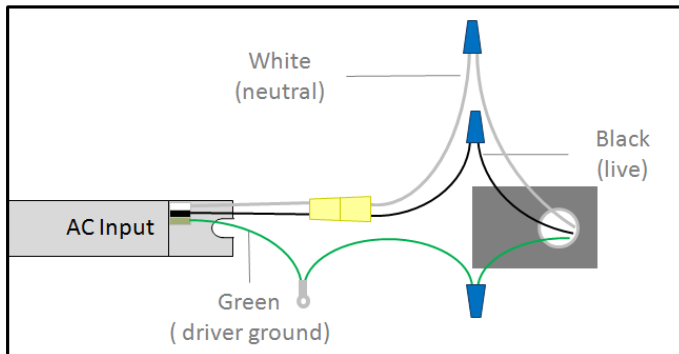

Diagram C: Magnified AC Connection Diagram

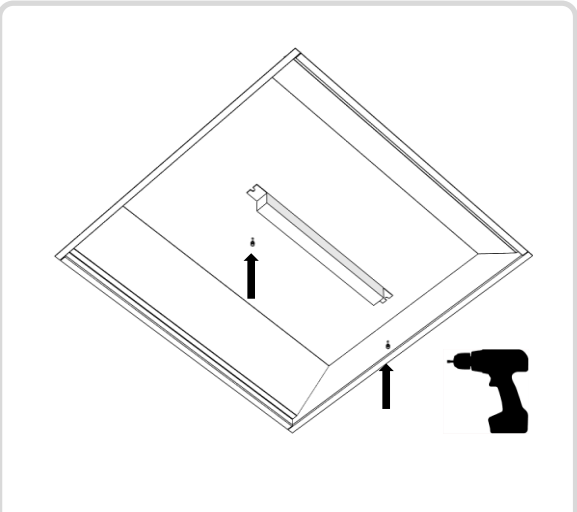

Diagram D: Examples of fluorescent fixtures before Retrofit
(Other fluorescent tube types and configurations are applicable)

1) Read all warnings AND installer notes before proceeding with this retrofit.

2) Check to ensure all parts listed are included in your retrofit kit. Optical diffuser is sold separately and should be accounted for before installation.

3) Disconnect power to the fixture.



6) Install LED driver using the two larger driver screws provided. Consider wiring to LED boards and reattachment of the ballast cover when determining where to mount the driver.

In some fixtures the LED driver may not fit within the existing ballast box or cover. In this case it will be necessary to install the replacement LED driver cover (sold separately).

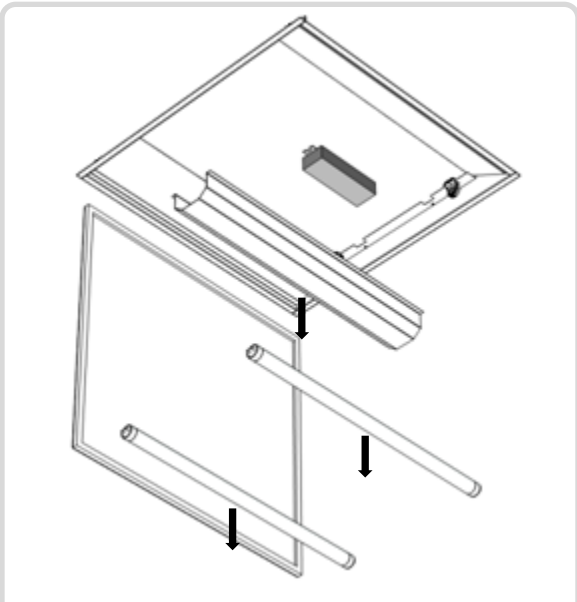

4) Remove the existing lens door or parabolic louver, fluorescent lamps, and fluorescent ballast cover. Set aside the ballast cover and the lens door or parabolic louver for future use. Dispose of tubes in proper accordance with current state and federal regulation. Fluorescent tubes contain hazardous materials.

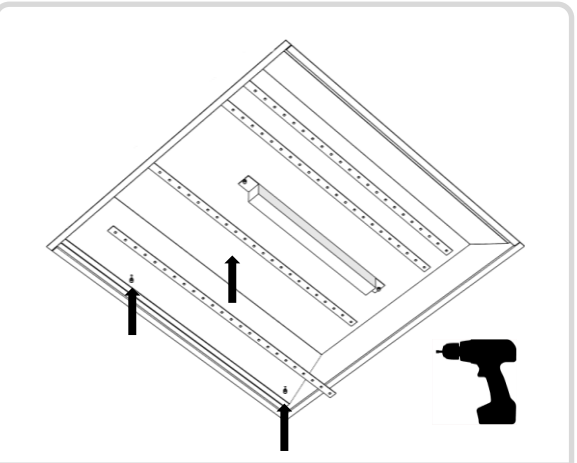

7) Install LED boards using 3 of the provided screws for each LED board. If using adhesive option, peel the protective film from the adhesive squares on the back of the LED Boards. Press boards firmly against fixture housing without touching LEDs.

When considering placement, use fluorescent lamp sockets as a guide. Optimal light distribution is typically achieved when LED boards are evenly spaced between the ballast cover and the edge of the fixture.

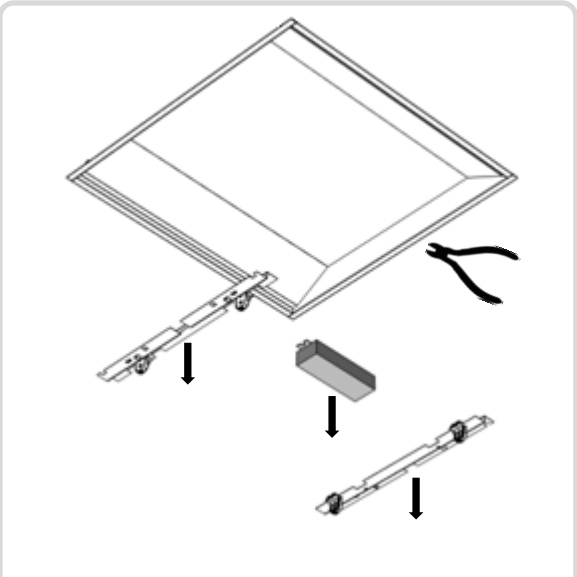

5) Disconnect or sever wiring at the fluorescent ballast and lamp holders. If space for the LED driver is limited, remove the ballast and dispose of it in proper accordance with current state and federal regulation. If space for the LED boards is limited, note the positions of the fluorescent lamp sockets and remove the fluorescent lamp holders.

7) (continued)

Avoid dimples, bumps, or uneven surfaces so that boards lay flat against the fixture housing. DO NOT touch LEDs, at risk of damaging them.

In some fixtures it may be necessary to mount LED boards onto the fixture's ballast cover. Mount LED boards on the cover while it is outside the fixture. Ensure that the screws will not make contact with the LED driver or damage any wiring when the cover is reinstalled.

8) Connect white wires to the LED boards and driver by pushing wire ends into the connectors according to either Diagram A or B, depending on the fixture dimensions. Use striped wires to make connections from positive (+) terminals to positive (+) terminals. Use plain wires to make connections from negative (-) terminals to negative (-) terminals.

Ensure that wires are locked into the connectors, and are NOT positioned where they may contact with edges of the ballast cover or other sheet metal.

9) Connect LED driver AC Input to AC power according to Diagram C using the provided wire nuts and quick-disconnect. Use only wires with no stripes.

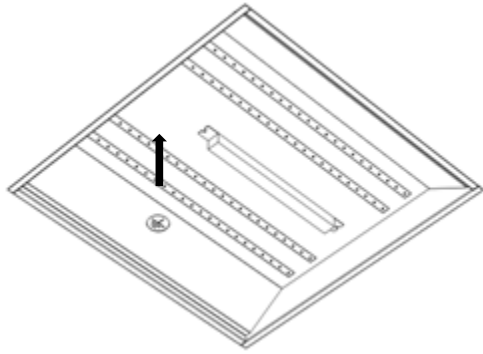

10) Attach Driver Ground (green) to the fixture housing according to Diagram C using provided green wire and self-drilling screw. The existing Earth Ground (green) wire may also need to be connected to the fixture housing using the same screw.

Adhere the Ground Marker Label to the fixture housing near the ground connection. This label is for safety purposes and is required by UL standards.

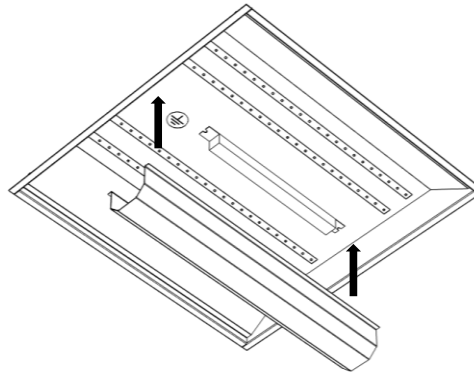

11) Reinstall ballast cover, ensuring that LED driver and AC wiring are completely enclosed.

No wires should cross under the edges of the ballast cover. Wires should exit the ballast cover from either end and should NOT be taut against sheet metal edges.

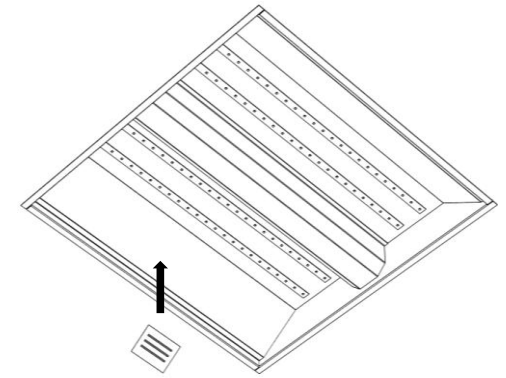

12) Adhere the Identification Label to the original fixture housing in a clearly visible location. The label shows the model number and date of manufacture, and it is required by UL standards.

13) If using the optional optical diffuser (sold separately), install over existing lens or louver so that the smooth side will face the LEDs.

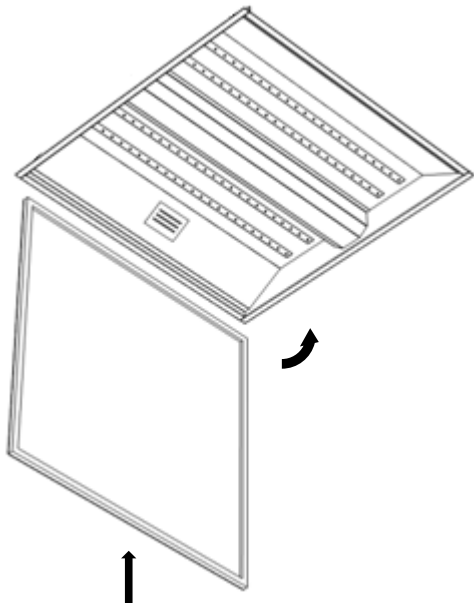

14) Re-install the lens door or parabolic louver.

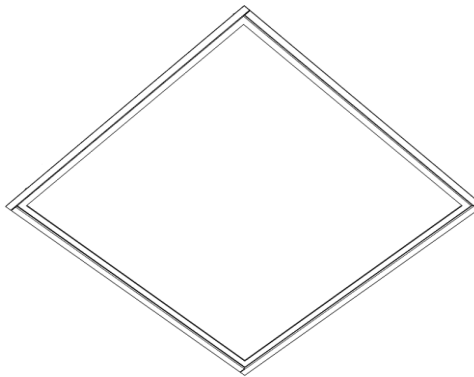

15) Reconnect the fixture to power to complete the installation.