



## Viewpoint Bird Spike Installation Guide

This installation instruction applies to all Viewpoint models. (VAS, VAM)

### Tools Needed

Drill with 8/32 Hex Head Nut Driver Bit

Hacksaw

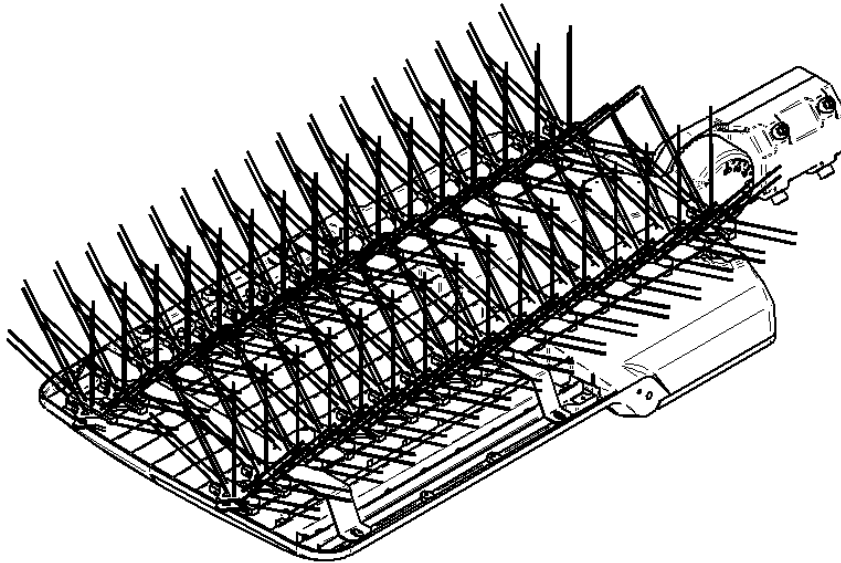

### **WARNING**

To avoid the risk of fire, explosion, or electric shock, this product shall be installed, inspected, and maintained by a qualified electrician, in accordance with all applicable electrical codes.

### **WARNING**

To avoid electric shock:

- Allow product to cool before servicing.
- Be certain electrical power is OFF before and during installation or maintenance.
- Luminaire must be connected to a wiring system with equipment-ground conductor.

## Installation Figures

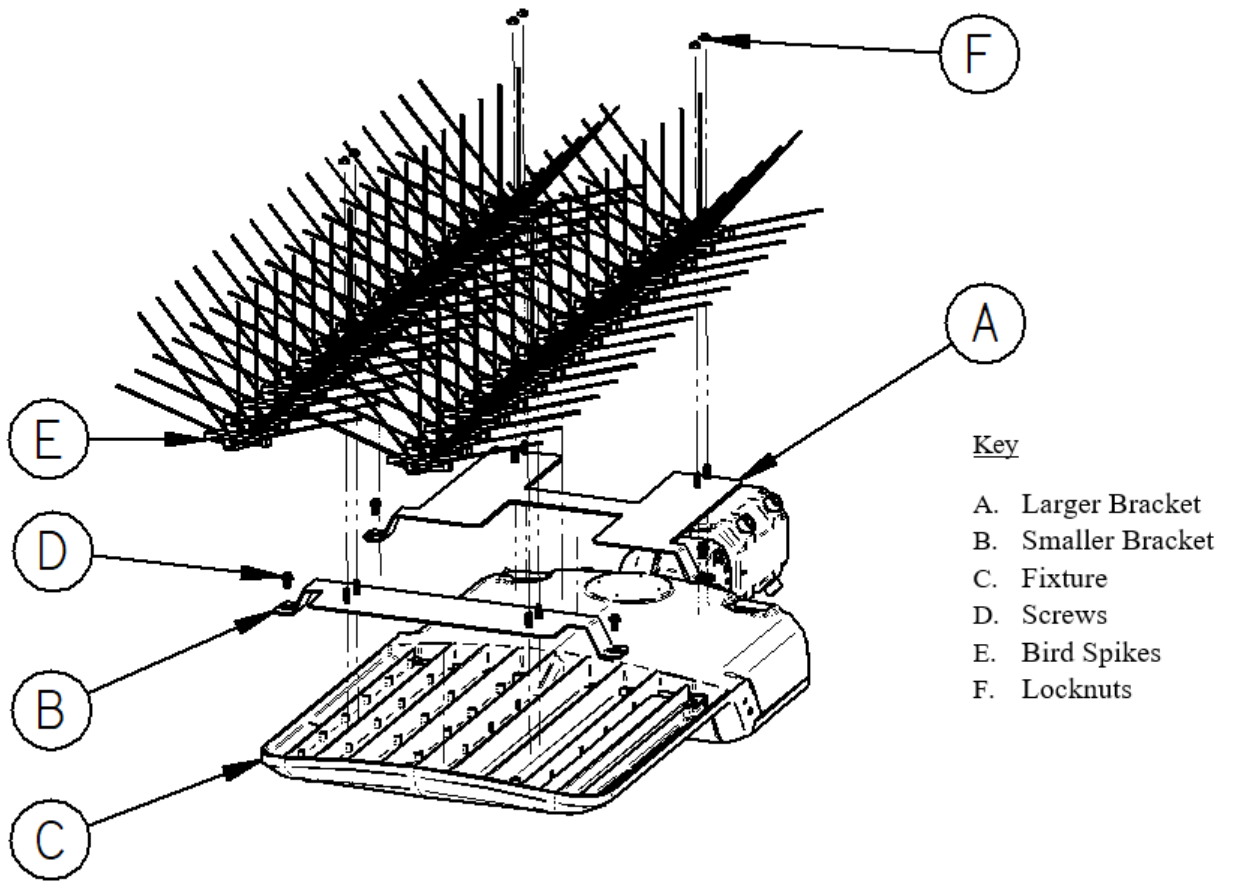

Figure 1 Bird Spike Assembly

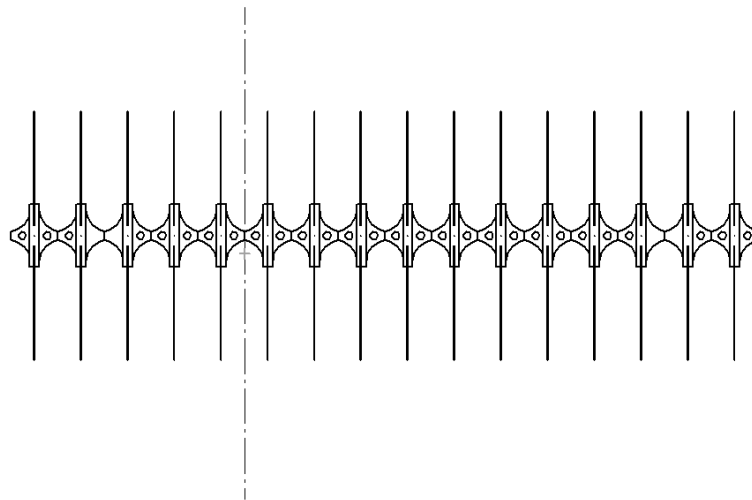

Figure 2 Bird Spike Trimming Location (FOR VAS ONLY)

## Installation Steps

**\*\*PLEASE NOTE:** For VAS Fixtures only, trim the Bird Spike as shown in Figure 2 before installation. **DO NOT** trim the Bird Spike when installing a VAM fixture.

1. If necessary, trim the Bird Spike (E) with hacksaw (see note above).
2. Attach the Larger Bracket (A) and Smaller Bracket (B) as shown to the Fixture (C) using the provided Screws (D). Ensure that the PEMs are facing upwards as shown above and Screws (D) are fully engaged.
3. Align the bird spikes (E) onto the eight PEMs of both Brackets (A&B) as shown. Use the Locknuts (F) to secure the bird spikes (E) to both Brackets (A&B)
4. Inspect the fixture to make sure that all the Screws (D) and locknuts (F) are fully tightened. Ensure that the bird spikes brackets are rigid (A, B, E).